

1. Dimensions:

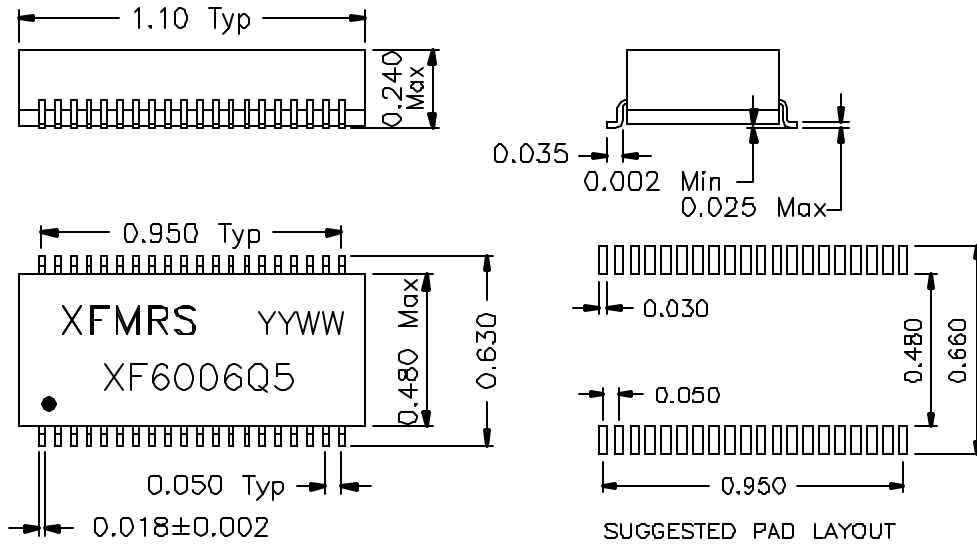

3. Electrical Specifications: @25°C

- Isolation: 1500 Vrms (PRI to SEC)
- TX Turns Ratio: 1:2CT ±2% (PRI:SEC)
- RCV Turns Ratio: 1:1CT ±3% (PRI:SEC)
- TX PRI OCL: 600uH Minimum @100KHz 50mV
- RCV PRI OCL: 600uH Minimum @100KHz 50mV
- Cw/w: 40pF Maximum @100KHz 50mV (PRI/SEC)
- TX PRI LL: 1.0uH Maximum @100KHz 50mV
- RCV PRI LL: 1.0uH Maximum @100KHz 50mV (SEC Shorted)
- DC Res.: Tx Pri 1.0 Ohms (SEC Shorted)
- DC Res.: Tx Sec 2.0 Ohms Max
- DC Res.: Rx Pri 1.2 Ohms Max
- DC Res.: Rx Sec 1.2 Ohms Max

2. Schematic:

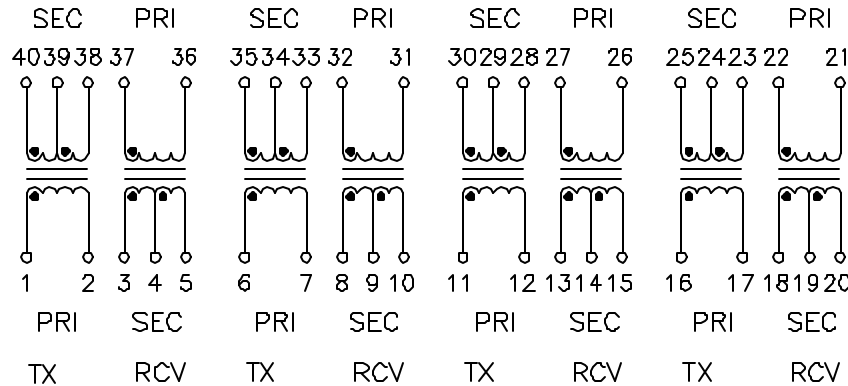

Notes:

- 1 Solderability Leads shall meet MIL-STD-202, Method 208D for solderability.
- 2 Flammability: UL94V-0
- 3 ASTM oxygen index: > 28%
- 4 Insulation System: Class F 155°C. UL file E151556
- 5 Operating Temperature Range: All listed parameters are to be within tolerance from -40°C to +85°C
- 6 Storage Temperature Range: -55°C to +125°C
- 7 Aqueous wash compatible
- 8 Designed to meet requirements of UL1950

DOC. REV A/2

THIS DOCUMENT IS STRICTLY NOT ALLOWED TO BE DUPLICATED WITHOUT AUTHORIZATION

XFMRS Inc	Title: T1/E1/CEPT QUAD PORT	
	UNLESS OTHERWISE SPECIFIED TOLERANCES: .xxx ±0.010	P/N: XF6006Q5
Dimensions in INCH	CHK. 康玉坤	Jan-25-00
SHEET 1 OF 1	APP. 李清儿	Jan-25-00
	APP. Joe Huff	Jan-25-00